

Quickdraw[®]

SYSTEMS

EB Conveyor Maintenance Guide



Table of Contents

• Overview	Page 3
• Exploded View Of A Standard EB Conveyor	Page 4
• Preventative Maintenance	Page 5
• Determining a Conveyors “Right” and “Left”	Page 5
• Routine Maintenance	Page 6 - 9
Powering Conveyors By Hand	Page 6
Edge Belt Replacement	Page 7
Setting Belt Tension	Page 7
Motor Replacement	Page 8
Replace Hanger Bearing	Page 9
• Non-Routine Maintenance	Page 10
• Electrical Controls Maintenance	Pages 11-19
Measuring Current Draw	Page 11
Integral Motor Control Card	Pages 12-15
Motor Card Wiring Diagram	Page 16
Motor/Conveyor Direction Change	Page 16
Setting Conveyor Speeds	Page 17
Phase Considerations	Page 18
Electrical Troubleshooting	Page 19
• Troubleshooting	Page 20
• Parts List	Page 21

Overview

Quickdraw Conveyors are designed to be the most reliable and easiest to maintain automated process conveyors available. This Guide consists of easy to understand maintenance procedures for your EB Series Conveyor. This Guide also contains a Troubleshooting Section to help technicians identify the potential causes of any problems that may occur.

If you require any assistance, technical support or have any questions, please contact Quickdraw's Customer Service Department at:

Quickdraw Systems

*Phone: 1-800-473-8837
(952) 935-6921*

Fax: (952) 933-5803

*Internet: www.qdraw.com
E-mail: info@qdraw.com*

**Quickdraw Systems
9650 Newton Avenue South
Bloomington, MN 55431**

Note: Some illustrations in this manual include features that may not match or be included on your conveyor system.

*Note: This maintenance manual is offered in the English language.
If other languages are required, Quickdraw is not responsible for translation.*

Exploded View of a Standard EB Conveyor

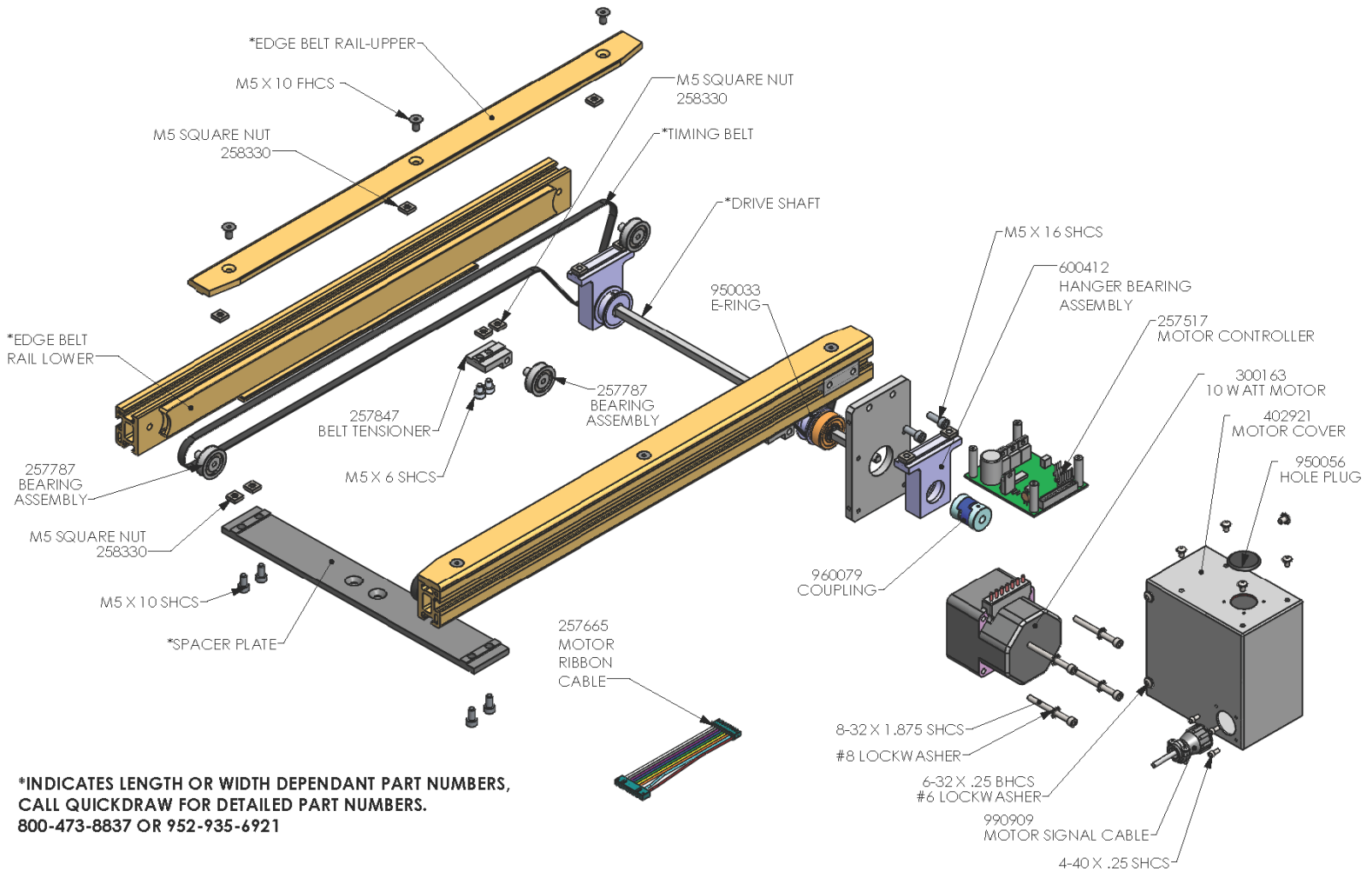

Preventive Maintenance

The following is a list of procedures that should be followed as a part of a regular maintenance routine.

Procedure :

- 1) Unplug the Conveyor Power Connector.
- 2) Check the Conveyor to make sure that all Pulleys and Belts are turning freely.
- 3) Check for wear on the Drive Belt and on the Timing Belts.
- 4) Check to make sure that the Drive Belt is properly orientated.
- 5) Check to make sure that the Drive Belt is in alignment and properly tensioned.
- 6) Check to make sure that the Conveyor is securely fastened to its frame.
- 7) Always hand-power the Conveyor after maintenance and before start-up.
- 8) Restore Power to the Conveyor.

Determining a Conveyor's "Right" and "Left"

Procedure:

- 1) View the Conveyor with the end containing the Motor closest to you.
- 2) As you view the Conveyor from this perspective, the Conveyor is divided into a left and a right side. Use this procedure to determine the correct part.

Routine Maintenance

Powering Conveyors by Hand

Powering the Conveyor by hand must be done after every maintenance procedure prior to connecting the power source. This is done to ensure the smooth, interference free, operation of the motor , belts and if applicable, rollers.

***Important:** Failure to hand-power a conveyor before turning on its motor may result in the following:*

- 1) Blown Fuse*
- 2) Timing Belt Damage*
- 3) Drive Assembly Damage*

Procedure:

- 1) Unplug Power to the Conveyor.
- 2) Turn the Drive Shaft with your fingers. Turn in both directions. **The last direction turned should be the same as the conveyor's direction of flow.*
- 3) To avoid problems, hand-power the conveyor as it is being assembled. *For example:* After assembling the Drive Shaft, hand-power the conveyor. After tensioning the Timing Belt, hand-power the conveyor. After replacing the Rail's Top Cover, then hand-power the conveyor.
- 4) Restore Power to the Conveyor.

Troubleshooting:

Many conveyor issues can be solved by systematically isolating parts or sections of the conveyor and either loosening or removing them from the system. As you do this with the power off, rotate the conveyor by hand until the movement feels smooth and unrestricted. For more specific instructions, see the Troubleshooting section on Page 20.

Routine Maintenance (Continued)

Edge Belt Replacement

Procedure:

- 1) Remove the Upper Rail.
- 2) Loosen the Belt Tensioner.
- 3) Remove the E-Rings and loosen the Coupling set screw.
- 4) Remove the old Edge Belt.
- 5) Place the new Edge Belt over the far end pulley.
- 6) Pull the Belt toward the Motor end. Put the belt on the teeth of the Drive Pulley.
- 7) Check the Edge Belt to ensure that it is not twisted or caught on the Rail.
**Turning the Drive Pulley with your fingers while you observe..*
- 8) Properly tension the belt (See Below).
- 9) Hand-Power the Conveyor (see page 6).
- 10) Replace the Top Rail.
- 11) Hand-Power the Conveyor.
- 12) Turn on the Conveyor.

Setting Belt Tension

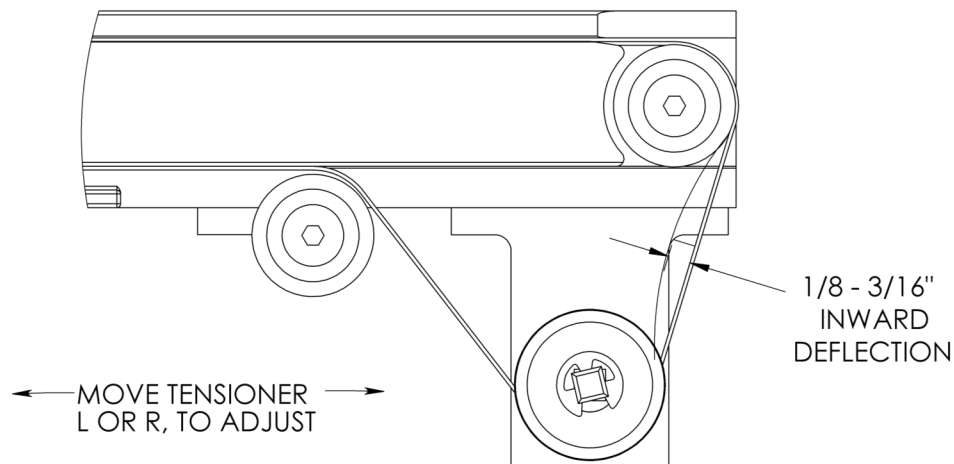

NOTE:

1. TENSION BELT BY LOOSENING TENSIONER SCREWS AND MOVING THE ASSEMBLY IN DESIRED DIRECTION TO OBTAIN THE APPROXIMATE VALUE ABOVE.

2. IF CONVEYOR OPERATION IS NOISY, RELAX TENSION TO LARGER VALUE.

Routine Maintenance (Continued)

Motor Replacement

- 1) Unplug power to the Conveyor.
- 2) Remove Motor Cover.
- 3) Disconnect cables from Motor.
- 4) Remove the long socket head screws holding the Motor to the Bracket. The Motor separates from the Conveyor at the Coupling. Remove the Motor with part of the Coupling. Keep the plastic center part of the Coupling for the Motor reinstall.
- 5) Measure or mark the location of the part of the coupling that is still attached to the Motor Shaft and then loosen the setscrew and remove it.
- 6) Install the new Motor, paying attention to locking the Coupling setscrew onto the flat on the Motor Shaft.
- 7) Rotate the Motor and Coupling parts so they mesh and reinstall the Motor, cables and Cover.
- 8) Hand Power the Conveyor (See Page 6).
- 9) Restore Conveyor power.

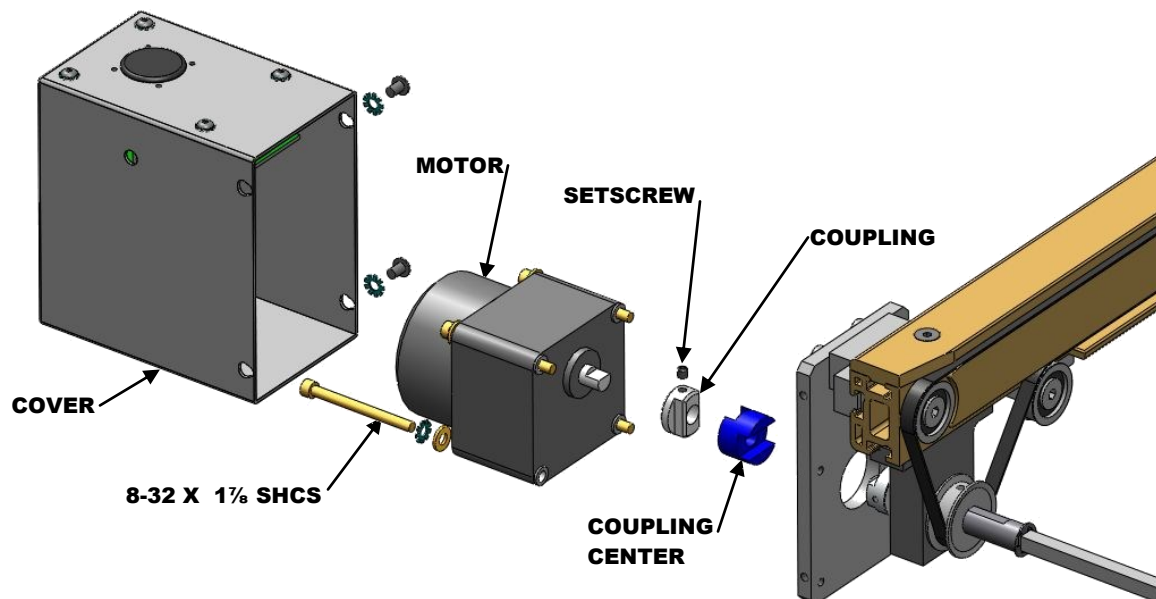

Routine Maintenance (Continued)

Hanger Bearing Replacement

- 1) Turn off power to the conveyor
- 2) Relieve belt tension by sliding back both Belt Tensioners.
- 3) Remove the Drive Shaft by loosening the near side Coupling setscrew.
Remove the inside E-Ring. Push the shaft towards the Motor and remove the E-Ring between the Motor and the Conveyor. Slide the Shaft out.
- 4) Loosen the Screws holding the Hanger Bearing to the Rail and slide out the entire Hanger Bearing assembly off the end of the Rail.
- 5) Remove the small C-Ring and slide out the square hole sleeve Bushing from the Bearing. Note the location of the spacer.
- 6) Using the correct tool, remove the large inside Snap Ring from the bracket.
- 7) Lightly and evenly tap the Bearing out of the housing.
- 8) Install the new Bearing using even pressure on the outer housing only.
- 9) Reinstall the components in reverse order. If the Pulley was removed, leave it loose and line it up after installation.
- 10) Hand power the conveyor. (See page 6).
- 11) Restore power to the Conveyor.

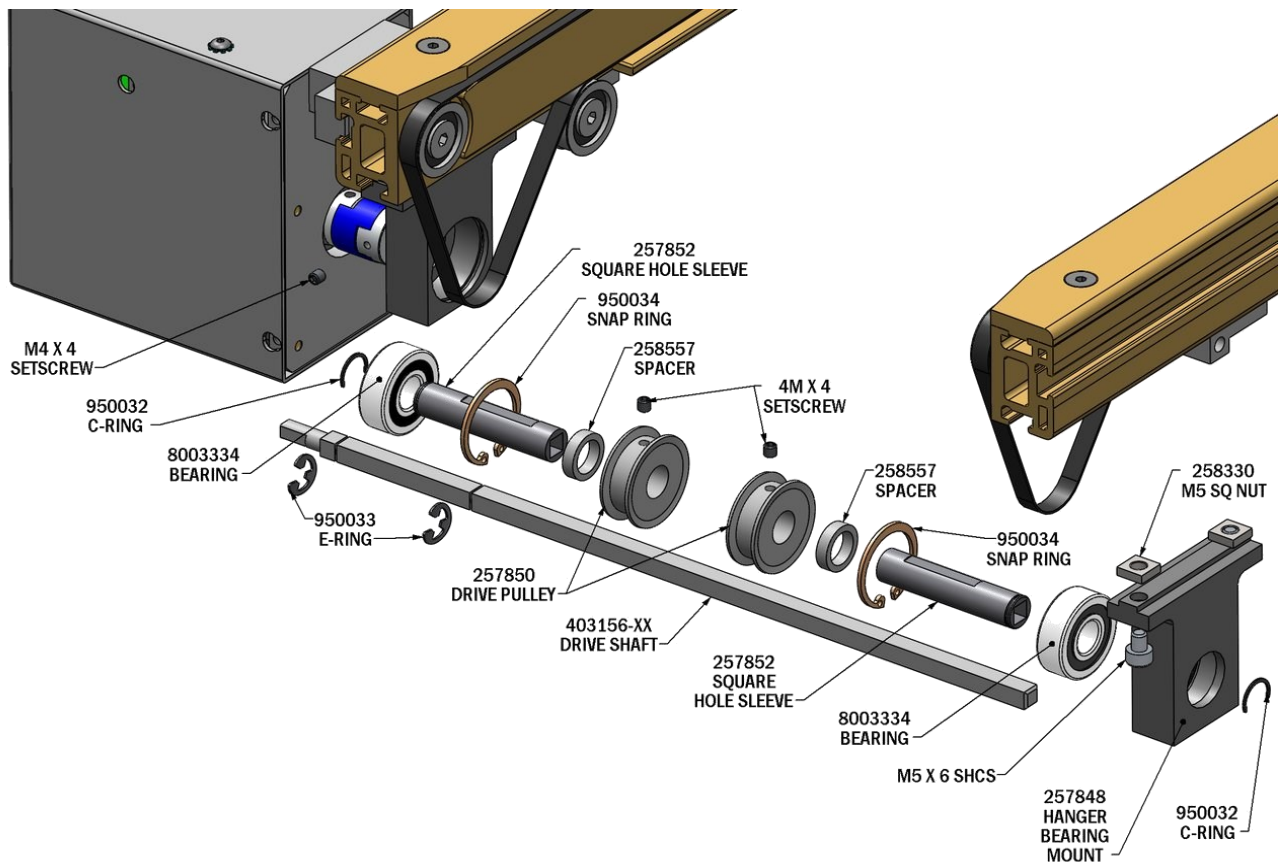

Non-Routine Maintenance

Top Rail Replacement

- 1) Remove the Top Rails.
- 2) Set new Top Rails in place.
- 3) Place a small amount of "Loctite 242" onto the threads of the Rail fasteners and re-install them.
- 4) Hand Power the Conveyor (See Page 6).
- 5) Turn on the Conveyor.

Electrical Controls Maintenance

Measuring Current Draw

Procedure:

Warning: This procedure describes testing in an open, powered Control Panel. Use caution.

- 1) In the Control Panel, open the Fuse Cover on the Fuse segment for that specific Conveyor. Opening the cover removes the fuse from the circuit.
- 2) With power on, carefully place the Ammeter's Probes on the screw heads as indicated in the diagram. The conveyor will "turn on". Take a reading on the meter.
- 3) If the reading is negative, reverse the probes.
- 4) The reading on a standard EB conveyor (unloaded - no product or pallet resistance) should be less than or equal to 0.50 amps.
- 5) If the reading exceeds this, see the Trouble Shooting -High Current section of this Manual on page #20.
- 6) Remove the Ammeter and close the Fuse segment cover. Close the Control Panel cover.

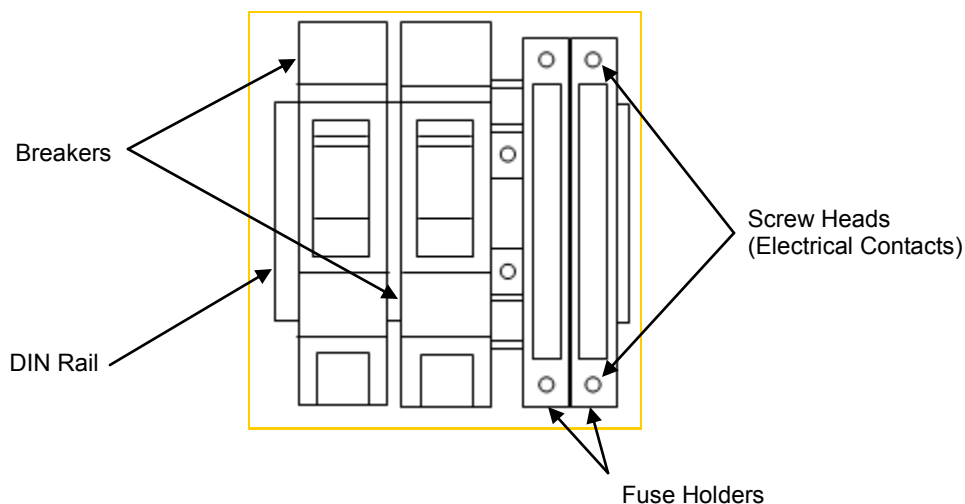

Example of Breakers and Fuse Holders mounted on DIN Rail inside a control Panel.

Note: Quickdraw Conveyors with a standard 10W Motor should draw no more than 0.50 amps unloaded.

Integral Motor Controller

Introduction:

Quickdraw's brushless DC (BLDC) motor controller commutates power into a standard three phase brushless (BLDC) motor up to a 10-watt motor. The BLDC controls (i.e. speed, direction, enabling) can be set by using jumpers or by giving external signals to connector P1.

Controller Dimension Diagram

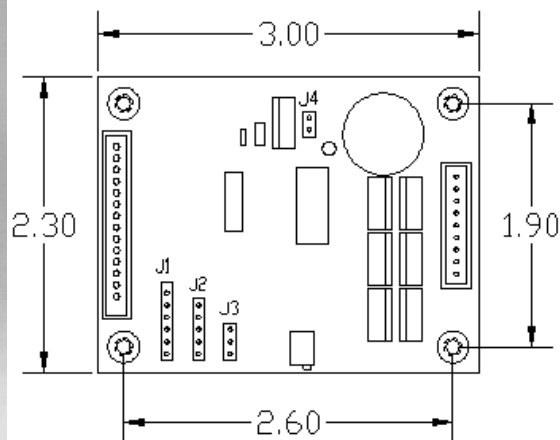
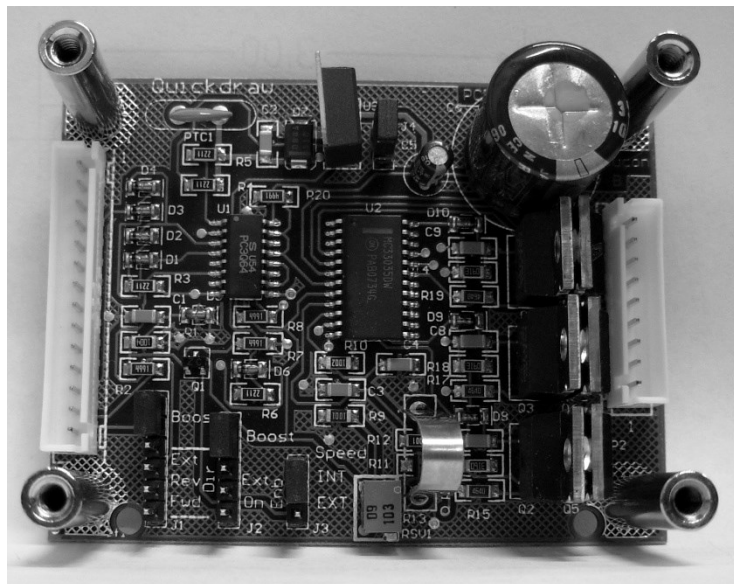

(6-32 tapped standoff on board)

Connections: Power and Control Signals, Brushless Motors and Hall Sensors.

Brushless Motors:

Brushless DC motors have eight (8) wires; three (3) phase lines to the motor, three (3) Hall sensor lines, and sensor power and common. Also BLDC motors come with two sensor configurations. 60, and 120 degrees and is connected to P2.

Quickdraw designed this controller to power Japan servo 3W and 10W motors, although other motors can be driven with this controller.

Motor Sensor Spacing:

Quickdraw's BLDC controller is shipped ready for 120-Degree sensor spacing. *(Note: The Japan Servomotors supplied on most Quickdraw conveyors use 120 Degree sensor spacing)* However, if 60-degree spacing is desired, remove the jumper across J4.

Power Requirements:

The power is supplied to this card using Pin 1 and Pin 14 on connector P1. The 24V input signal should be fused with a 1-amp slow blow fuse. The power should be off until the hookup procedure is complete and you are ready to run.

Integral Motor Controller, Cont'd

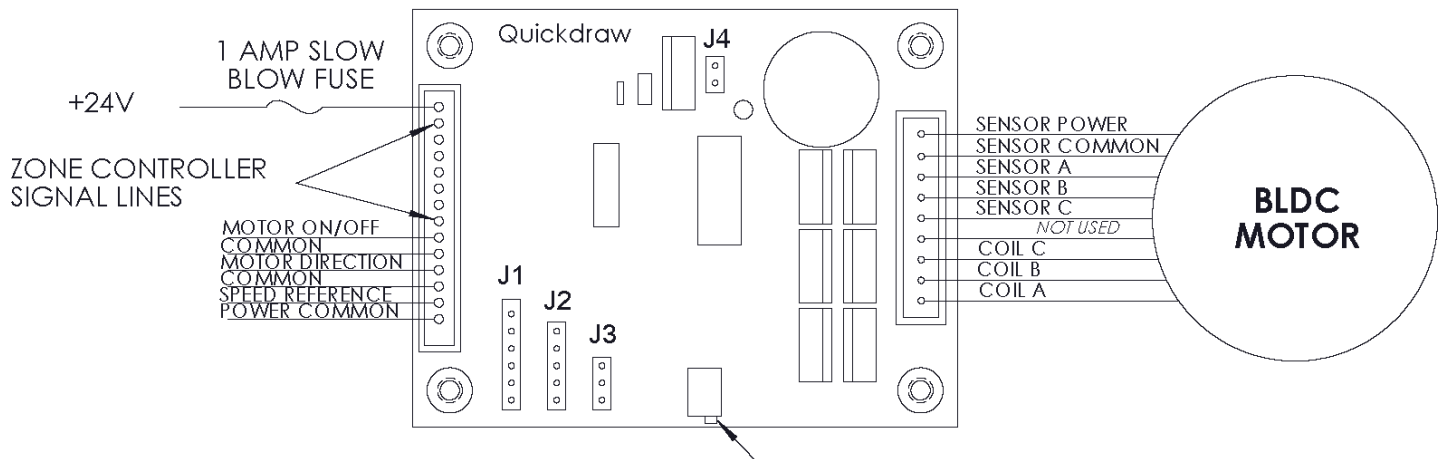

Motor Speed Control:

Quickdraw's BLDC controller comes with two speed control options. The different control options can be selected by changing the position of jumper J3 on the motor controller board. When internal speed control is selected with the jumpers, the motor references the multi turn pot (RSV1) on the controller board for speed. The speed can be increased or decreased by turning the pot with a non-conducting screwdriver.

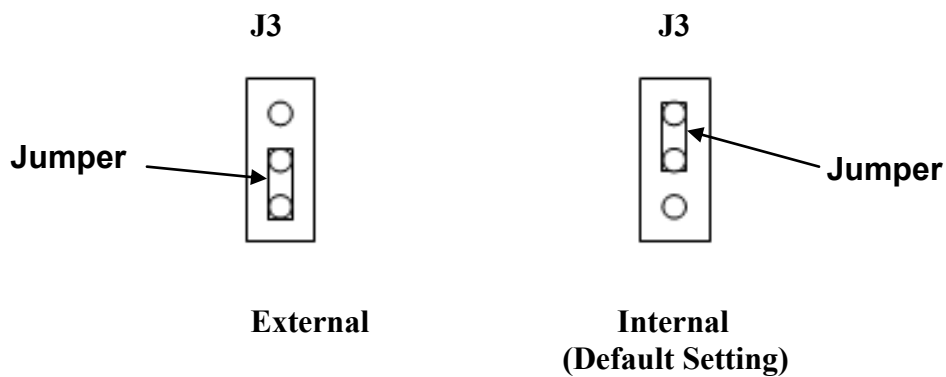

Motor Controller speed control options.

When the external speed control is selected, the speed pot is disabled and the motor gets its speed reference from an external 2-5V signal. This signal should be reference to the controller's common.

Motor Enabling Control:

Quickdraw's BLDC controller has three modes for controlling the motor: boost, external enable, and always on.

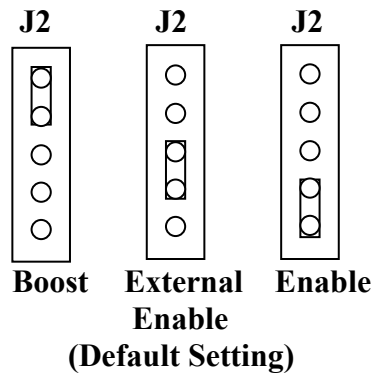

Motor Controller Enabling Options.

Motor Boost mode uses control signals from another controller and amplifies those signals for use on higher wattage motors. These connections are made through P1.

Motor External Enable mode uses the control signal on P1-9. This pin is brought to common P1-10 through a jumper wire, switch, relay, or an open collector NPN transistor.

Motor Enable mode; the motor is always on.

Unless specified otherwise by the customer, the default setting for this jumper is “External Enable”.

Motor Directional Control:

Quickdraw's BLDC controller has four modes for controlling the motor direction: boost, external direction, always forward, or always reverse. This controller is not designed for plug reversing. Damage to the controller could happen by not stopping it first.

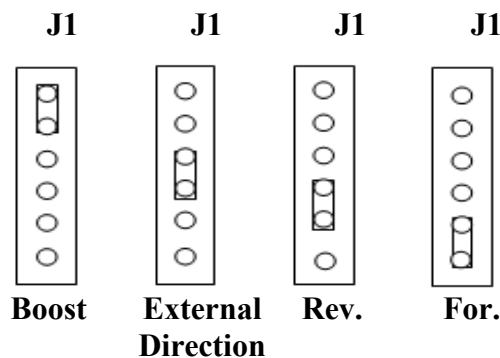

Motor Controller Directional options.

- Motor direction is specified by the Customer.
- Motor Boost mode uses directional control signals from another controller and amplifies those signals for use on higher wattage motors. These connections are made through P1.

- Motor External Direction mode uses the control signal on P1-11. This pin is brought to common P1-12 through a jumper wire, switch, relay, or an open collector NPN transistor.
- Motor Forward mode, the motor will always rotate clockwise (view facing shaft end).
- Motor Reverse mode, the motor will always run counterclockwise.

SPECIFICATIONS:

BOARD OUTSIDE DIMENSION.....	2.3" x 3"
MOUNTING HOLE DIMENSION.....	1.9" x 2.6"
INPUT VOLTAGE	24Vdc
OUTPUT VOLTAGE	0 to 24Vdc
MOTOR HALL SPACING (jumper selectable)	60° or 120°
LOAD CURRENT (continuous)	2.5 Amps continuous
SPEED RANGE	0-100%, full range
INPUT CONNECTIONS	14-pin JST
OUTPUT CONNECTIONS	9-pin JST
SPEED COMMAND SIGNAL	2-5Vdc
DIRECTIONAL COMMAND SIGNAL	Switched to common
MOTOR CONTROL SIGNAL	Switched to common
OPERATING TEMPERTURE	32° - 95° F
INTERNAL VOLTAGE SUPPLY (for hall sensors)	6.25 Volts

Conveyor Interface

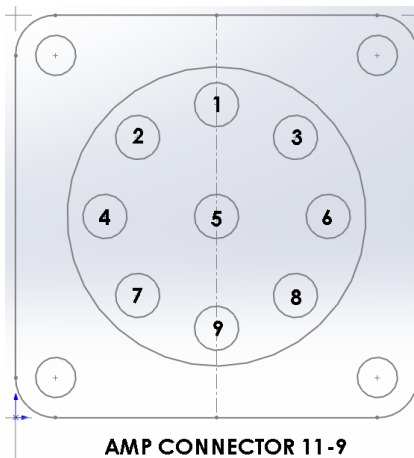

AMP CONNECTOR 11-9
Quickdraw PN-980413

PIN #	DESCRIPTION	<u>STANDARD</u> CABLE COLOR	<u>FLEX</u> CABLE COLOR
1	+24V Source	Orange	Pink
2	Motor ON/OFF	Brown	Brown
3	Motor ON/OFF Common	Red	Red
4	Motor Direction	Black	Gray
5	Motor Direction Common	White	White
6	Speed Reference (0-5VDC)	Blue	Blue
7	Source Common	Green	Green
8	N/C	X	X
9	N/C	X	X

Motor Control Card Wiring Diagram

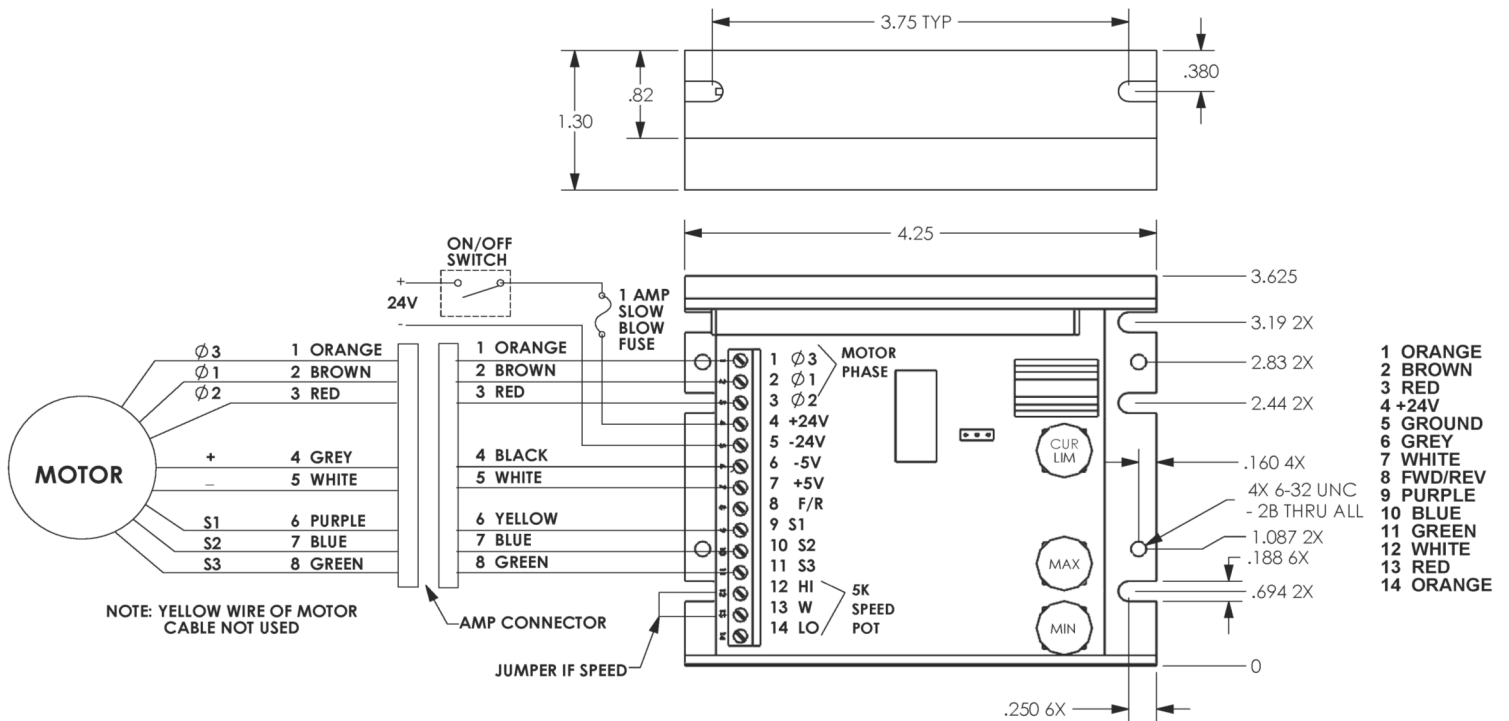

Wiring Diagram For The Dart 730BDC

Please Note: The enclosed Speed Pot is connected as follows:
 White to 12; Red to 13; and Orange to 14. To eliminate the Speed Pot, jumper Terminals 12 & 13 and set speed using on-board controls.

Motor Cable Wiring Guide

	Pin	Ribbon Cable		Pin	8 Conductor Cable
 AMP Connector Receptacle Numbering Sequence	1	Orange		1	Orange
	2	Brown		2	Brown
	3	Red		3	Red
	4	Grey		4	Black
	5	White		5	White
	6	Purple		6	Yellow
	7	Blue		7	Blue
	8	Green		8	Green
					 AMP Connector Receptacle Numbering Sequence

Note: the Yellow Wire is Not Used on the Ribbon Cable.

Procedure to Change direction— Dart DC Brushless 730BDC Card:

- 1) Unplug power to Conveyor.
- 2) Locate the Motor Control Card that is operating in the wrong direction.
- 3) Turn off power.
- 4) Unplug the Conveyor Control Box from electrical power.
- 5) Check the Control Card for a wire jumper connecting Terminals #5 and #8.
- 6) If there is a jumper wire, remove the wire to change the direction of flow.
- 7) If there is no jumper, insert a wire jumper to change the direction of flow.
- 8) Plug in the Conveyor Control Box.
- 9) Turn on the power.

Setting Conveyor Speeds

Unless otherwise requested, Quickdraw sets all Conveyor Speeds at 60 ft./min. for all Conveyor Systems that include Conveyor Control Boxes. Quickdraw does this to standardize its conveyor performance data. The Motor Cards used on most applications come with Speed Potentiometers (Speed Pots) that can either be used or discarded. Most customers choose not to use the Speed Potentiometers, but rather set speed with Min/Max Speed Pots directly attached to the board.

How To Determine Conveyor Speed

Procedure:

- 1) Place a piece of non-reflective tape around the motor shaft Coupling or Drive Shaft Sleeve. * *This is done to ensure that the Tachometer is reading only the reflection of the special reflective tape.*
- 2) Place a small piece of reflective tape onto the other tape.
- 3) Turn on the conveyor.
- 4) Measure the rpm with a Handheld Optical Digital Tachometer, such as the "AMETEK Model 1726 Optical Digital Tachometer".

How To Convert Linear Distance/Minute to Target RPM

Procedure:

- 1) Establish the needed conveyor flow rate. * *For example: 60 ft/min.*
- 2) Determine the pitch diameter of the Drive Pulley. * *A #257850 T80 x 40 tooth Drive Pulley (typical) has a pitch diameter of 1.02"*
- 3) Use the following formula to determine the target rpm:
 - Target RPM = Linear Speed (ft/min) / { π *diameter (in feet)}
 - Target RPM = 60 ft/min. / π * (1.02"/12"/ft)
 - Target RPM = 60 ft/min. / π * 0.085 ft.
 - Target RPM = 60 ft/min. / 0.267 ft.
 - Target RPM = 224

Procedure For Conveyors Equipped With Dart 730 BDC Control Cards:

With Speed Pot:

- 1) Turn the dial on Speed Pot until the tachometer reads target rpm.
- 2) If unable to achieve target rpm, adjust the white Min and Max dials found on the Motor Control Card until the target rpm can be achieved within the range of the Speed Pot.

Without Speed Pot:

- 1) Adjust the white Min and Max dials found on the Motor Control Card until the target rpm can be achieved.

Phase Considerations

For most applications, Quickdraw Systems uses low voltage, Brushless DC 3-Phase Motors and Control Cards. Occasionally, a faulty phase may be the problem. Signs of a bad phase include but are not limited to:

- a) Intermittent Motor Failure.
- b) The ability to start the Motor by turning the Collar Clamp or Motor Shaft after initial powering-up of the Conveyor. After the Motor has been finger started, the Motor turns on its own, but again may intermittently have a start up problem.

To remedy this situation, follow the Electrical Troubleshooting guide on the following page. Make certain to turn the Conveyor on and off multiple times to make sure that the real cause of the problem is found.

Electrical Troubleshooting

Procedure:

- 1) Check all electrical connections. Make sure that all plugs are connected properly.
- 2) Make sure that it is an electrical problem by eliminating the Conveyor as a possible cause of failure:
 - a) Measure the current draw (See Page 11).
 - b) Hand power the Conveyor.
 - c) Attach the Conveyor to a Motor Cable that is connected to a different, functioning Motor Control Card. ** Use a different Conveyor Control Box if possible.*
 - d) Measure the current draw.
- 3) If the Conveyor turns by hand, and operates within an acceptable current draw range when connected to a different Motor Control Card, the problem lies somewhere in the original electrical system.

Possible causes include:

 - a) Electrical connections.
 - b) The Motor.
 - c) The Motor Cable.
 - d) The Power Supply.
- 4) To check the Motor, plug the electrical system in question into a different Conveyor. If the new Conveyor operates properly, the Motor on the original Conveyor is probably the cause and should be replaced.
- 5) To check the Motor Cable, switch Cables with a Conveyor that is operating properly. If the problem disappears, check the original Cable for bad electrical connections or cuts. If the original Cable cannot be repaired, then it must be replaced.
- 6) Unplug the Conveyor Control Box and check for loose connections or cut wires within the Control Box. Be careful not to create additional problems by pulling too forcefully on the wires. If you believe that you have found loose wiring and have taken steps to reconnect them properly, plug in the Control Box and measure the current draw of the original system. If the current draw is within the acceptable range, you have fixed the problem. If not, proceed to step #7.
- 7) If you still have not found the problem, replace the Motor Card using the Wiring Diagram on Pages 13, 15 & 16 as a guide.
- 8) If this does not eliminate the problem, please call a Quickdraw Systems representative for support at 1-800-473-8837 or (952) 935-6921.

Troubleshooting

Important: *When performing any maintenance, make certain that the Drive Assembly is free to turn before applying power to the Motor.*

Problem	Possible Cause(s)	Solution
Conveyor Belts are not tracking properly.	a) Are the pulleys improperly aligned? b) Are the belts frayed? c) Are the Covers on tightly?	a) Inspect and adjust pulley alignment using a straightedge. b) Replace damaged or worn belts. c) Loosen and retighten the Covers to ensure that the Guides are in contact with Timing Belt.
The Motor is not turning.	a) Is a fuse blown? b) Is the speed adjustment turned down? c) Is there a faulty connection? d) Is the Motor Control Card receiving 24VDC?	a) Replace blown fuse. b) Adjust the speed on the Motor Control Card. c) Check to see that the Motor is plugged in and no wires are loose on the Motor Control Card. d) Use a volt meter and check the potential across terminal numbers 4 and 5 of the Control Card.
The Motor will turn, but only when started by hand.	a) If the Motor will not start on its own, but will run if manually started, the Motor Control Card is likely at fault. b) Is it a faulty Motor or Motor Control Card? c) Is it a bad wire connection?	a) Replace the Control Card. b) Try another Motor on this Control Card and/or this Motor on another Control Card. Replace the defective component. c) Check the connections between the Motor Control Card and the Motor. Repair any loose connections.
Motor Fuses continually blow. (High Current)	a) Is the Conveyor assembled correctly? b) Is it a bad Motor or Motor Control Card?	a) Check that the Drive Assembly turns easily by hand. b) Try another Motor on this Control Card and/or this Motor on another Control Card. Replace the defective component.

Conveyor Components Parts List

<u>Part Number</u>	<u>Description</u>
257517	Motor Controller PCB
257665	Motor Ribbon Cable
257847	Belt Tension Block
257848	Hanger Bearing Mount
257850	Drive Pulley
257852	Square Hole Sleeve
258330	M5 Square Nut
258557	Spacer
258946	Motor Mount Bracket
*300163	10W Motor W/DD Modification
*	Drive Shaft
*	Edge Belt Upper Rail
*	Edge Belt Lower Rail
*	Belts have unique part numbers - Call
402412	Motor Mount Standoff
402921	Motor Cover
404357	Mounted D-Drive 730 (730BDC)
505460	Coupling
600105	Bearing Assembly
600412	Hanger Bearing Assembly
8003334	Bearing
950032	C-Ring
950033	E-Ring
950034	Snap Ring
950056	Hole Plug
990908	Motor Signal Cable
990909	IC Cable

* Contact Quickdraw Systems for exact part numbers for various width and length driven components.

Additional Support:

Contact Quickdraw Systems if you have any questions or need parts that aren't listed on this page.

Phone: 1-800-473-8837 or (952) 935-6921

Fax: (952) 933-5803